



# SEA<sup>®</sup>



## Automatic Gate Openers

International registered trademark n. 804888

### **SATURN**

**600-1000-2000 (230V-115V)**

**1500 24V (230V-115V)**

**1200 24V FAST**

**500 SUPER FAST 24V (230V)**

**800 BR 36V BRUSHLESS**

### **BOXER**

**1000 - 2000**

**2000 Threephase**

**MOTOR REDUCERS FOR SLIDING GATES**



**SEA S.p.A.**

Zona industriale Sant'Atto - 64020 Teramo - (ITALY)

Tel. +39 0861 588341 r.a. Fax +39 0861 588344

[www.seateam.com](http://www.seateam.com)

[seacom@seateam.com](mailto:seacom@seateam.com)

# GENERAL FEATURES

**SATURN** and the **BOXER** are gearmotors designed for the automation of sliding gates. The operators are available in **version with grease** lubrication or in **oil bath version**. The irreversibility of the gearmotors allows a perfect and safe closing of the gate avoiding the installation of the electric lock and, in the event of a power failure, the release device placed on the front part allows the manual opening and closing. **The operators are equipped with an electronic clutch device (some versions of adjustable mechanical clutch)**, which guarantees an adjustment of the thrust on the gate. In addition, **the electronic inversion system (optional) through Encoder**, makes the **SATURN** and **BOXER** gearmotors safe and reliable operators, allowing in a simple way to comply with the regulations in force in the countries where the product is installed.

## MAIN COMPONENTS

E.g. Saturn

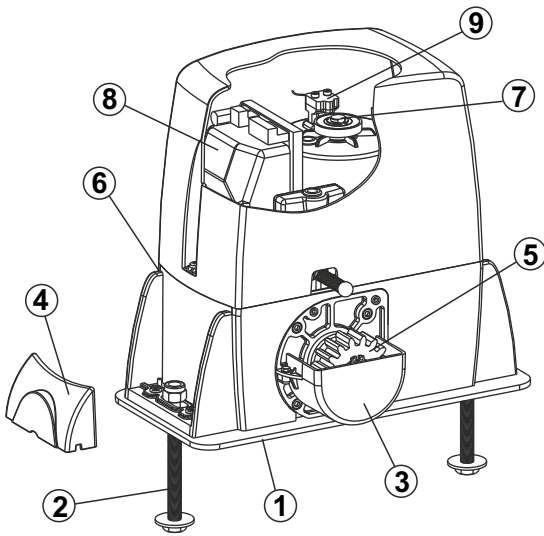

- 1 Adjustable foundation plate
- 2 Anchor bolts
- 3 Pinion protection
- 4 Adjusting screws cover
- 5 Pinion
- 6 Reducer release lever
- 7 Screw for mechanical clutch adjustment (Optional)
- 8 Electronic unit
- 9 Magnetic encoder (Optional)

## DIMENSIONS (mm)

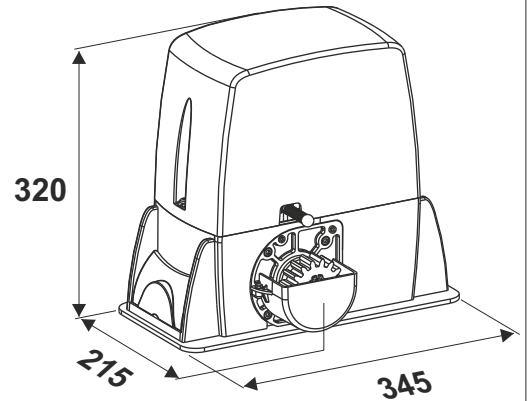

## GRAPHIC OF USE

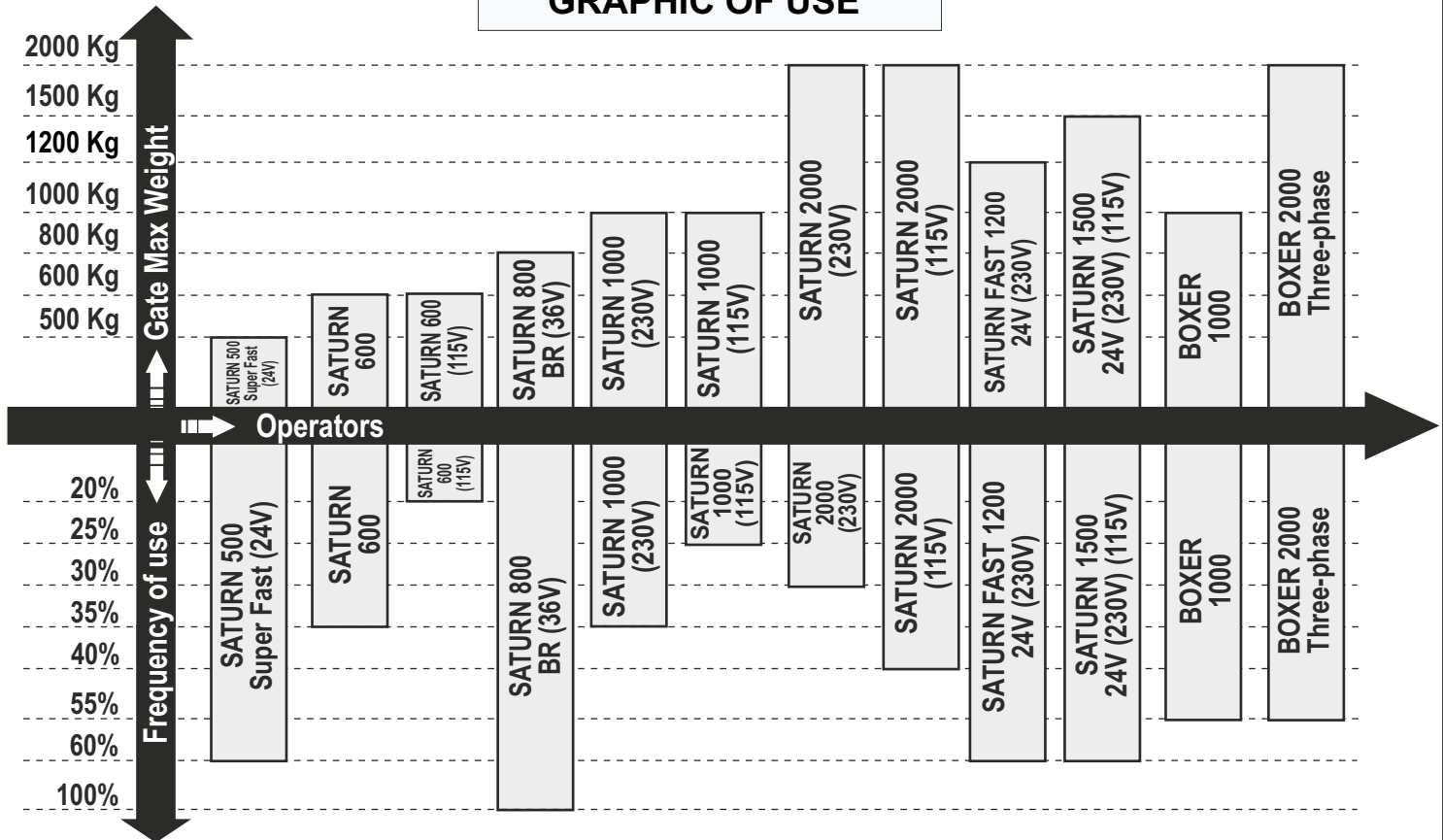

## TECHNICAL FEATURES

TECHNICAL DATA	SATURN 600 - 1000 - 2000 (230V)			SATURN 600 - 1000 - 2000 (115V)		
	SATURN 600	SATURN 1000	SATURN 2000	SATURN 600	SATURN 1000	SATURN 2000
Power supply	230V~ ± 5% - 50/60 Hz			115V~ ± 5% - 50/60 Hz		
Power	320W	350W	600W	400W	700W	
Absorbed current	1,5 A	1,7 A	1,8 A	3,2 A	5,0 A	
Motor capacitor	16 µF	20 µF	25 µF	50 µF	70 µF	
Working frequency	55%			20%	25%	40%
Working Temperature	-20°C ↕ +55°C ↕			-20°C ↕ +55°C ↕		
Thermoprotection	150°C			150°C		
Weight	12,5 Kg	13 Kg	14,5 Kg	12 Kg	13 Kg	14,5 Kg
Anticrushing clutch	Electronic/Mechanical			Electronic		Elect./Mech.
Protection degree	IP55			IP55		
Pinion Z16 (Z20) speed	0,15 (0,18) m/s			0,15 (0,18) m/s		
Maximum torque	30 Nm	55 Nm	70 Nm	50 Nm	55 Nm	70 Nm
Gate maximum weight	600 Kg	1000 Kg	2000 Kg	600 Kg	1000 Kg	2000 Kg
Gate maximum length	6 m	10 m		6 m	10 m	
Mechanical clutch	If foreseen by the model			No		Yes
Limit switch	Inductive or Mechanical or Magnetic			Inductive or Mechanical		

TECHNICAL DATA	SATURN 800 BR 36V BRUSHLESS	SATURN 500 SUPER FAST 24V (230V)	SATURN 1200 FAST 24V (230V)	SATURN 1500 24V (230V)	SATURN 1500 24V (115V)
Power supply	230V~ ± 5% - 50/60 Hz				115V~ ± 5% - 50/60 Hz
Motor	36V $\equiv$	24V $\equiv$			
Absorbed power	330 W	100W			
Working frequency	100%	60%			
Working Temperature	-20°C ↕ +55°C ↕				
Weight	14 Kg	14,3 Kg			
Anticrushing clutch	Electronic				
Protection degree	Ip55				
Pinion speed	0,24 m/s Max (Z16)	0,40 m/s Max (Z20)	0,32 m/s Max (Z16)	0,25 m/s Max (Z13)	
Maximum torque	700 N	0 - 45 Nm	0 - 60 Nm	0 - 65 Nm	
Gate max. weight	800 Kg	500 Kg	1200 Kg	1500 Kg	
Gate maximum length	10 m				
Limit switch	Inductive or Mechanical				

TECHNICAL DATA	BOXER 1000	BOXER 2000	BOXER 2000 Three-phase	NOTES	
Power supply	230V~ ± 5% - 50/60 Hz		230V/380V (±5%) 50/60Hz	The indicated frequency of use is valid only for the first operating hour and at a 20°C room temperature	
Power	350W	700W	400W		
Absorbed current	1,7 A	1,8 A	1,0 A		
Motor capacitor	20 µF	25µF	-	In the versions SATURN and BOXER with INVERTER, the max speed allowed by the different pinions is shown in the following table:	
Working frequency	70%		50%		
Working Temperature	-20°C ↕ +55°C ↕				
Thermoprotection	150°C		-	SATURN 1000/2000 INVERTER BOXER 1000/2000 INVERTER	
Weight	14 Kg	15 Kg			
Anticrushing clutch	Electronic/Mechanical		Mechanical	PINION Z13	Max. 0,21 m/s
Protection degree	IP55			PINION Z16	Max. 0,266 m/s
Pinion Z16 (Z20) speed	0,15 (0,18) m/s			PINION Z20	Max. 0,33 m/s
Maximum torque	55 Nm	70 Nm			
Gate maximum weight	1000 Kg	2000 Kg			
Gate maximum length	10 m				
Mechanical clutch	If foreseen by the model				
Limit switch	Inductive or Mechanical				

# INSTALLATION PROCEDURE

## 1. GATE ARRANGEMENT

Before the installation check if all the gate parts (fixed and mobile) have a strong and non-deformable structure; also make sure that :

- a) The leaf is rigid and compact;
- b) The lower gate slideway is perfectly straight, horizontal and without any obstacles which could obstruct the gate sliding;
- c) The lower sliding wheels are equipped with greasable or watertightened bearings;
- d) The upper gate slideway has been produced and placed so that the gate is in a perfect vertical position;
- e) The mechanical stops of the leaf are always installed in order to avoid possible derailment of it.

## 2. FOUNDATION PLATE ANCHORAGE

To install the foundation plate it is necessary to:

**2.1.** Prepare a concrete basement according to the dimensions shown in Fig. 1; The foundation plate and the anchor bolts will be concreted inside the basement

**NOTE:** If allowed by the gate structure, it is recommended to lift the foundation plate of about 50mm from the ground, in order to avoid eventual water stagnation.

**2.2.** Before cementing the plate insert a flexible plastic pipe of at least 30 mm in diameter into the special hole of the plate

**2.3.** Before concreting the plate, make sure that it is perfectly levelled and that the distance of 58-67 mm as shown in Fig. 2 is respected

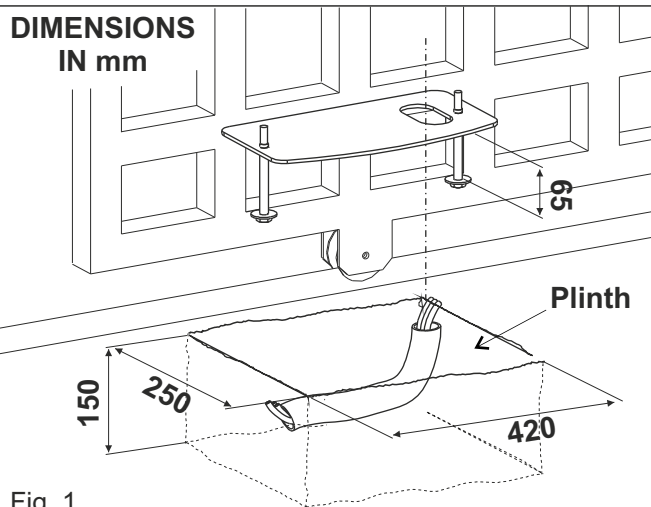

Fig. 1

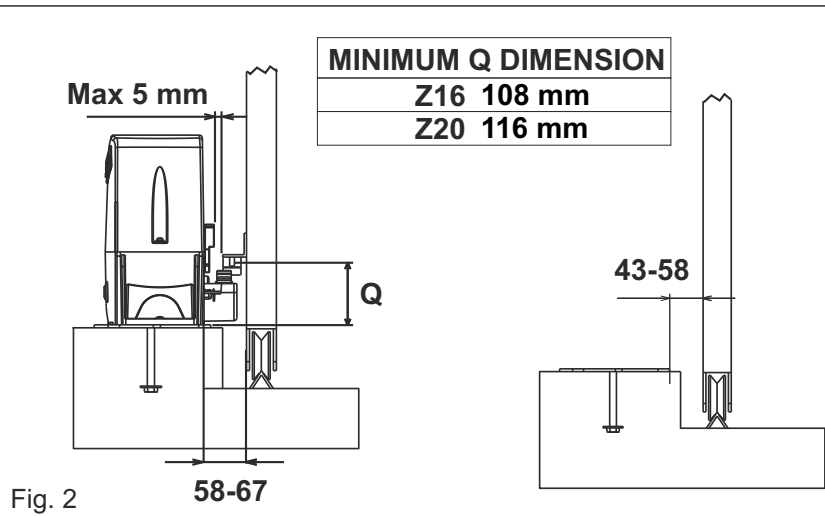

Fig. 2

## 3. CABLES PASSAGE ARRANGEMENT

Saturn and Boxer are provided with two different holes for electric cables passage.

It's very important to make the low - tension 230V~ cables pass through one hole and the very low safety tension 24V cables through the other one (Fig. 3)

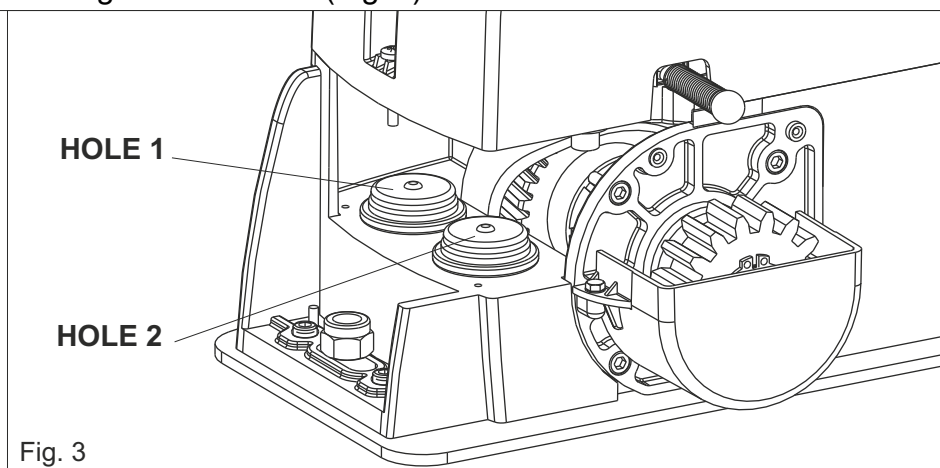

Fig. 3

## 4. FITTING OF THE MOTOR REDUCER

**4.1.** Insert the 4 grub screws into the special holes, in order to adjust the gearmotor height on the plate (Fig. 4) **At the end of installation check if the 4 grub screws are well gripped on the foundation plate**

**4.2.** Fix the gear motor to the foundation plate using the 2 included nuts, adjusting the side position (Fig. 5) so to respect the shown quota in Fig. 2



**ATTENTION! REMOVE THE RED TRANSPORT OIL CAP AND REPLACE IT WITH THE BLACK ONE SUPPLIED, PROVIDED WITH AIRHOLE**

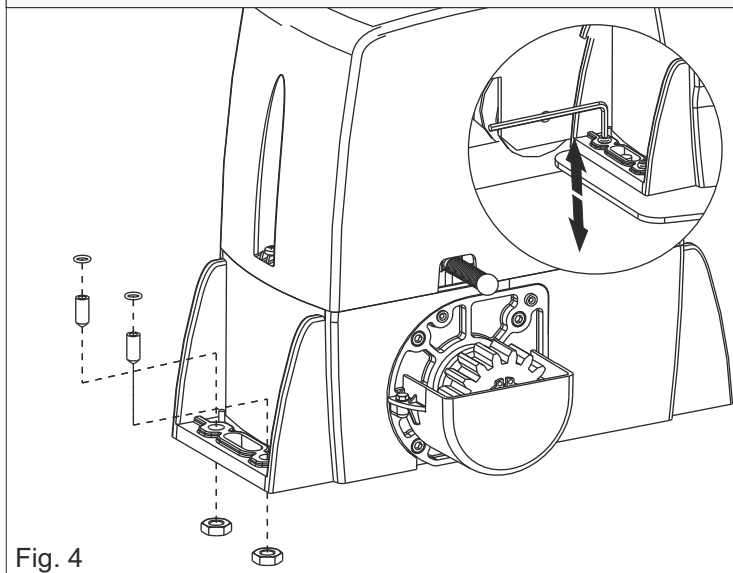

Fig. 4

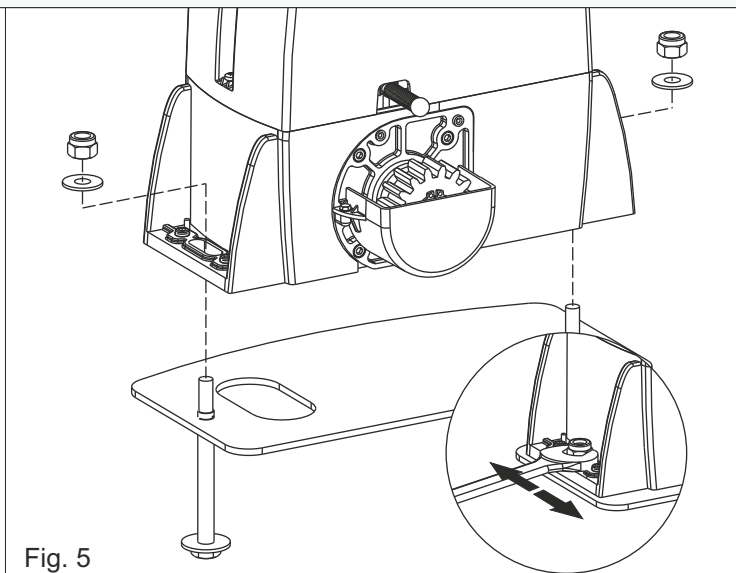

Fig. 5

## 5. GEAR RACK MOUNTING

**5.1.** Release the operator and open the leaf completely;

**5.2.** Fix on each gear rack element the support pawls with the appropriate lock screws, making sure to put them in the upper part of the hole (Fig. 6) ;

**5.3.** Lean the gear rack element on the toothed pinion of the operator in parallel to the ground slideway of the gate, as shown in Fig. 7 and electrically weld the central pawl **B** to the gate structure (Fig. 8). Manually move the gate until pawl **C** is placed in front of the pinion and fix it through electric welding. Repeat the same procedure for pawl **A** after having placed it in front of the pinion;

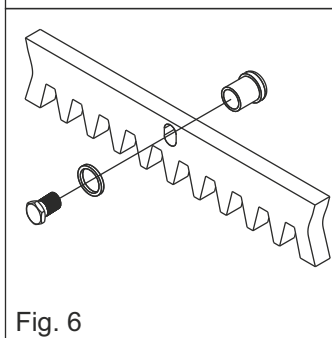

Fig. 6

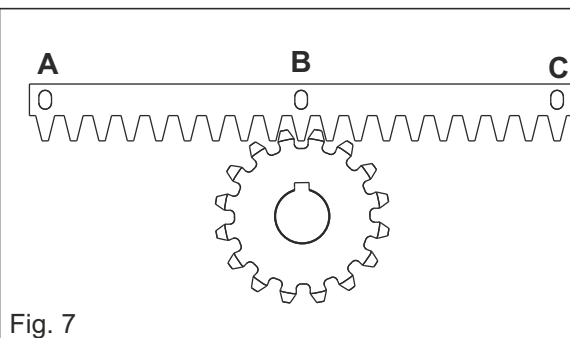

Fig. 7

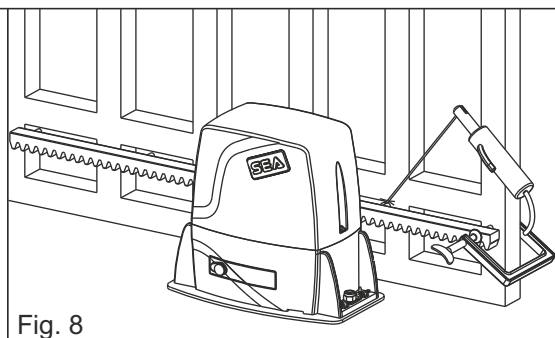

Fig. 8

**5.4.** Make sure that all the gear rack elements are perfectly aligned and correctly placed (teeth must be in phase). It's suggested to oppose an element to two aligned elements as shown in Fig. 9;

**5.5.** Repeat the above described operation for all the remaining gear rack elements which have to be installed;

**5.6.** To avoid that the gate weights down the pinion (Fig. 10) lift up the whole rack about 1,5 mm.

**Warning:** Keep a gap of about 0,5 mm between pinion tooth and gear rack tooth;

**5.7.** Make sure that the gear rack works at the midpoint of the pinion along all the rack elements, if necessary, adjust the length of the spacers

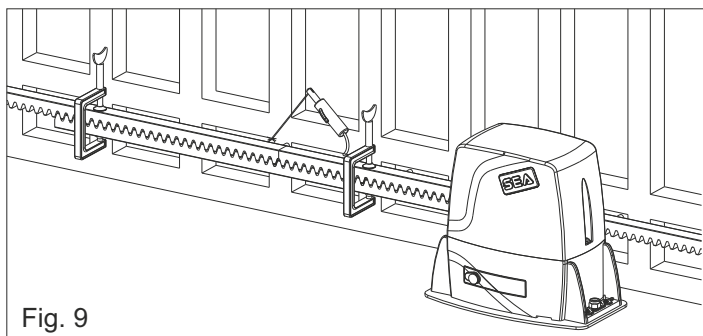

Fig. 9

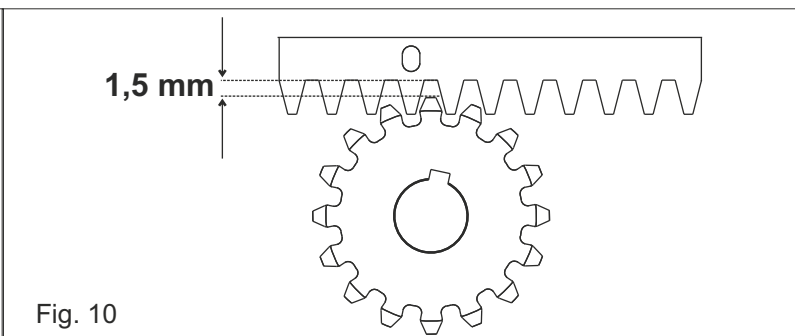

Fig. 10

## 6. ADJUSTMENT OF THE LIMIT SWITCH

### 6.1. IN OPENING

- Fully open the gate
- **MECHANICAL STOP:** place the plate (Fig. 11) on the rack according to the desired gate stop position (Fig. 14); fix the plate on the rack using the supplied screws.
- **INDUCTIVE LIMIT SWITCH:** place the plate (Fig. 12) on the rack according to the desired gate stop position (Fig. 14); fix the plate on the rack using the supplied screws. Bring the inductive limit switch opening plate (indicated by an arrow on the limit switch) in correspondence with point «X» of the plate on the rack (50 mm from the folded side of the plate - Fig. 13).

### 6.1. IN CLOSING

- Fully close the gate
- **MECHANICAL STOP:** place the plate (Fig. 11) on the rack according to the desired gate stop position (Fig. 14); fix the plate on the rack using the supplied screws.
- **INDUCTIVE LIMIT SWITCH:** place the plate (Fig. 12) on the rack according to the desired gate stop position (Fig. 14); fix the plate on the rack using the supplied screws. Bring the inductive limit switch closing plate (indicated by an arrow on the limit switch) in correspondence with point «X» of the plate on the rack (50 mm from the folded side of the plate - Fig. 13).

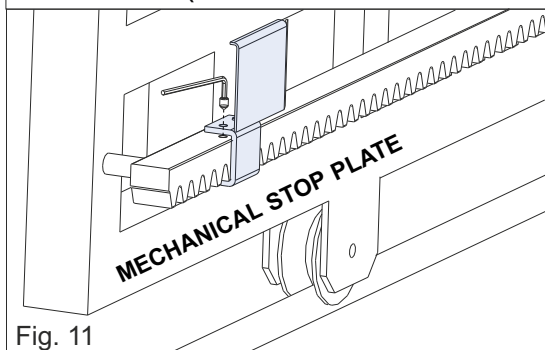

Fig. 11

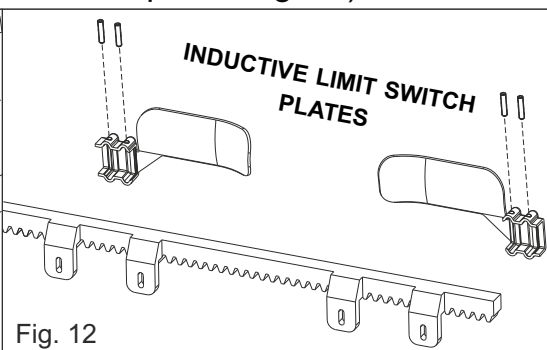

Fig. 12

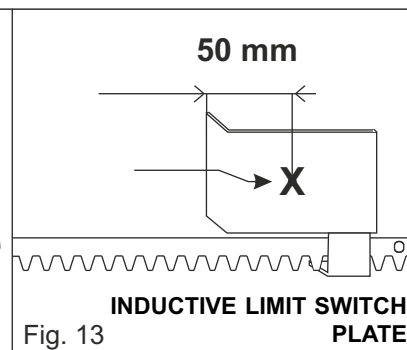

Fig. 13

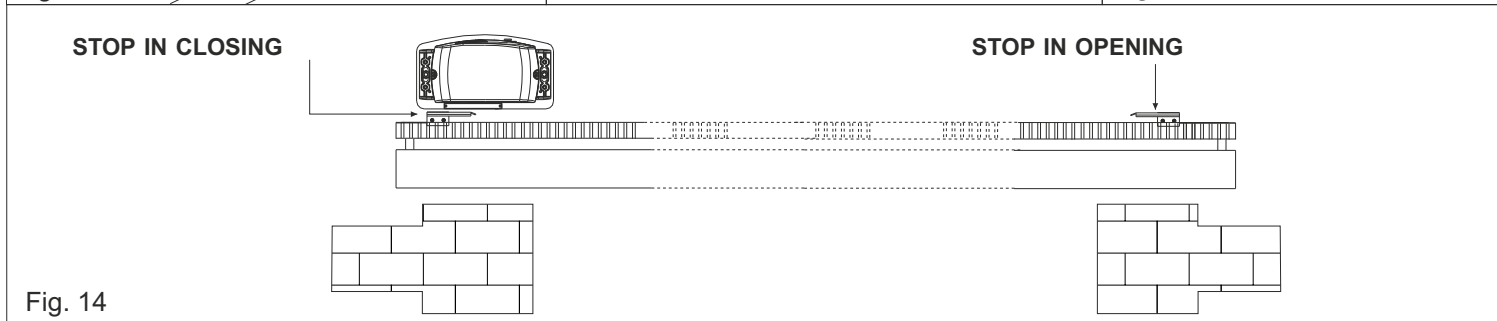

Fig. 14

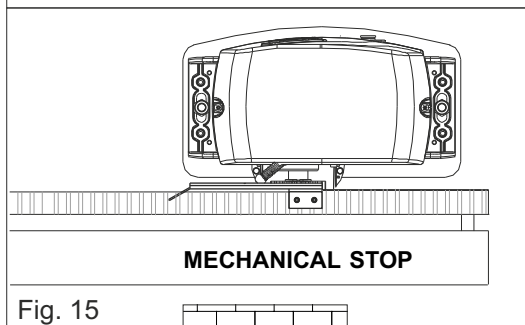

Fig. 15

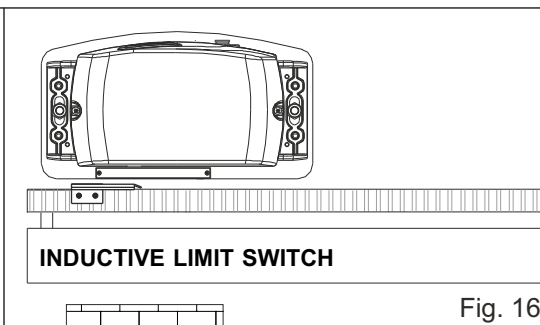

Fig. 16

### NOTE

FOR FURTHER DETAILS ON THE ADJUSTMENT OF THE INDUCTIVE LIMIT SWITCH, REFER TO THE PROGRAMMING MANUAL OF THE ELECTRONIC CONTROL BOARD

## 7. MAGNETIC LIMIT-SWITCH ADJUSTMENT

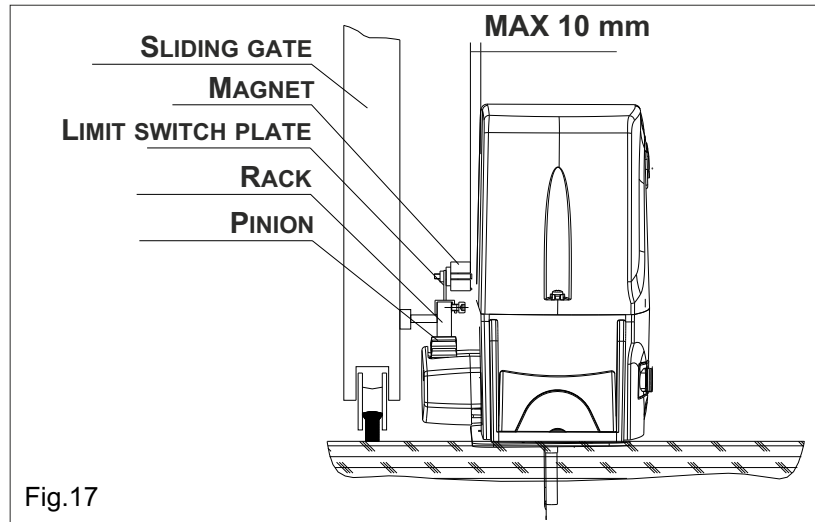

Fig.17

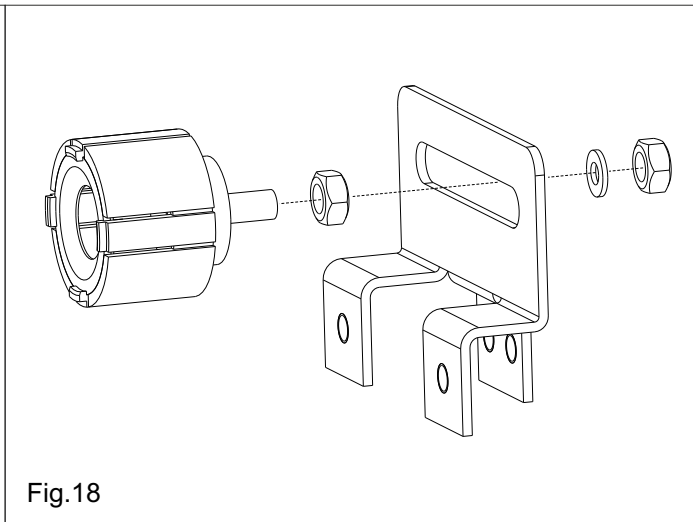

Fig.18

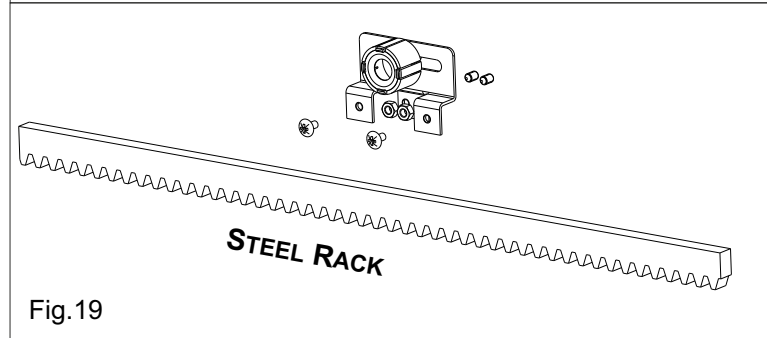

Fig.19

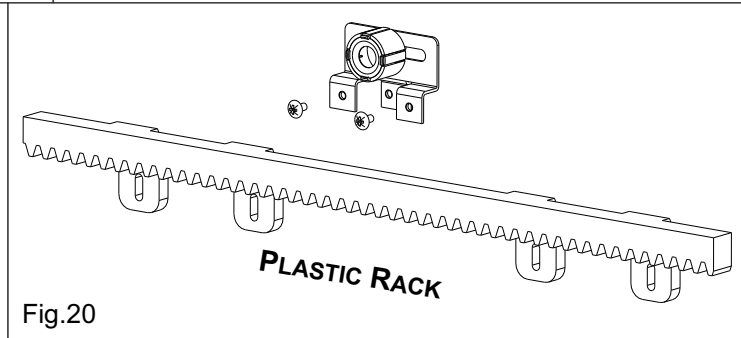

Fig.20

## 8. GROUNDING

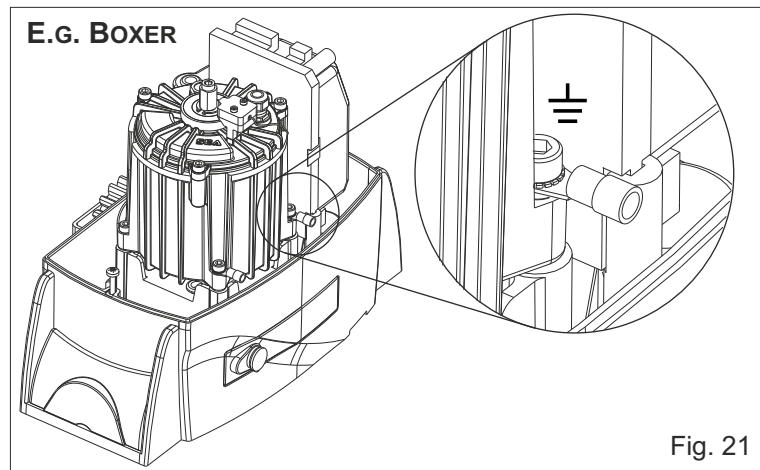

Fig. 21

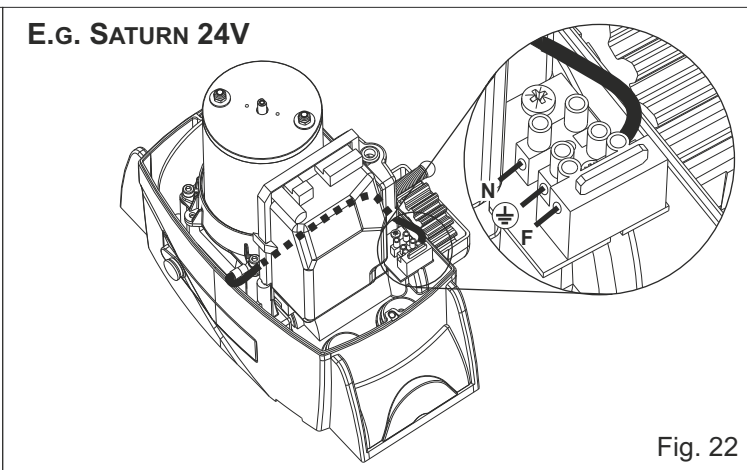

Fig. 22

## 9. CLUTCH ADJUSTMENT (Optional)

9.1. Switch off the electric power supply

9.2. In order to adjust the clutch, act on the grub screw "A" (Fig. 23) as follows:

- **Turning clockwise** = less clutch sensibility / more thrust force
- **Turning counter-clockwise** = more clutch sensibility / less thrust force

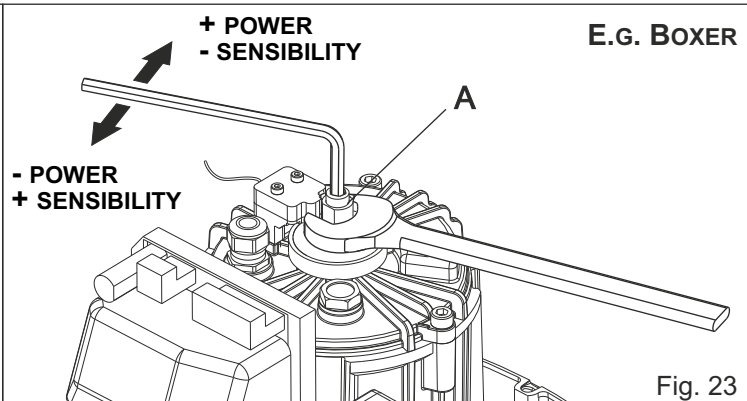

Fig. 23

## 10. SCREW COVER MOUNTING

At the end of the mechanical installation and after having executed all the required adjustments, mount the two screw covers on the operator as shown in Fig. 24

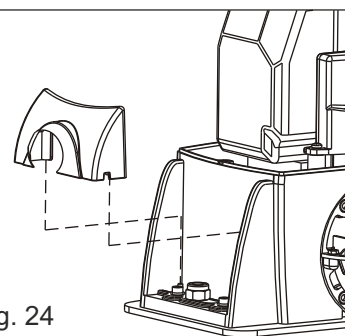
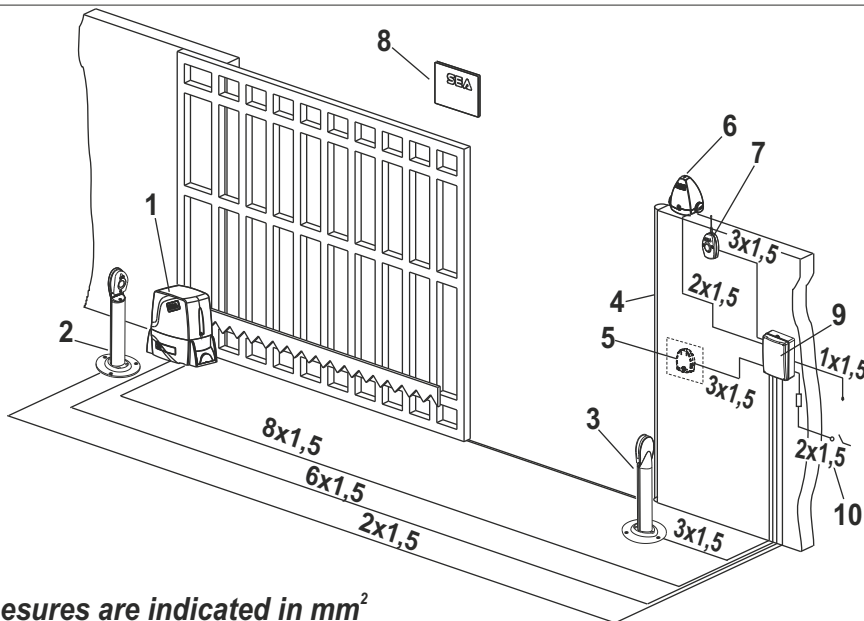

Fig. 24

## 11. ELECTRIC CONNECTIONS OF THE INSTALLATION

Fig. 25



The cable measures are indicated in mm<sup>2</sup>

- 1) Saturn - Boxer
- 2) Left photocell
- 3) Right photocell
- 4) Mechanical safety edge
- 5) Key button
- 6) Flash lamp
- 7) Receiver
- 8) Warning notice
- 9) Junction box
- 10) Differential 16A - 30mA

E.g. 230V version with integrated electronic control unit

## PART FOR BOTH INSTALLER AND END-USER



all unlocking and locking operations and all periodic maintenance operations must be carried out in the absence of power supply

## 12. RELEASE SYSTEM FOR SATURN AND BOXER

### 12.1. To release the operator:

- Open the lock cover, insert the key and rotate 90° clockwise (Fig. 26)
- Pull the release lever until it stops, about 90° approximately (Fig. 27)

**Note: when pull the release lever, the control unit receives a safety stop impulse thanks to a micro-switch inside the operator (anyway it is highly recommended to switch OFF the power supply before)**

### 12.2. To lock the operator:

- Push the release lever to complete closing.
- Rotate the key counter-clockwise and extract it.
- Close the protective lock cover.

**Once the lock has been restored the electronic control unit reactivates if the power supply was ON**

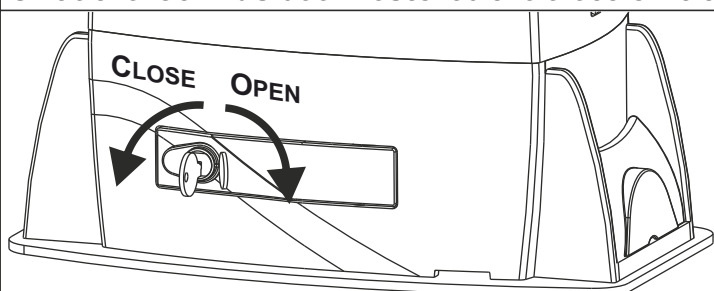

Fig. 26

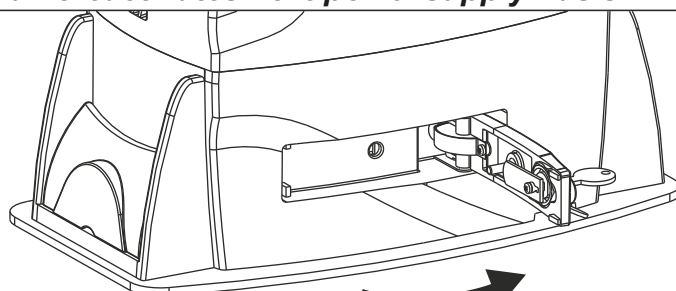

Fig. 27

**PART FOR BOTH INSTALLER AND END-USER**

**PERIODIC MAINTENANCE**

Check the oil level (for operators in oil-bath) by the use of the oil level rod	Annual
Change oil (for operators in oil-bath)	4 years
Check the release good functioning	Annual
Check the clutch functionality (for operators with clutch)	Annual
Check the distance between pinion and gear rack (1.5 mm)	Annual
Check the condition of the pinion and the gear rack (if overused or damaged)	Annual
Check the fixing screws	Annual
Check the connection cables integrity	Annual
Check the limit switch functionality and status in opening and closing; also check the condition of the stop plates	Annual



**ALL OPERATIONS MUST BE CARRIED OUT EXCLUSIVELY BY AN AUTHORIZED INSTALLER**

**RISK EXAMINATION**

The points pointed by arrows are potentially dangerous. The installer must take a thorough risk examination to prevent crushing, conveying, cutting, grappling, trapping so as to guarantee a safe installation for people, things and animals (Re. Laws in force in the Country where installation has been made). As for misunderstandings that may arise refer to your area distributor or call our help desk. These instructions are part of the device and must be kept in a well known place. The installer shall follow the provided instructions thoroughly. SEA products must only be used to automate doors, gates and wings. Any initiative taken without SEA explicit authorization will preserve the manufacturer from whatsoever responsibility. The installer shall provide warning notices on not assessable further risks. SEA in its relentless aim to improve the products, is allowed to make whatsoever adjustment without giving notice. This doesn't oblige SEA to upgrade the past production. SEA can not be deemed responsible for any damage or accident caused by product breaking, being damages or accidents due to a failure to comply with the instructions herein. The guarantee will be void and the manufacturer responsibility will be nullified if SEA original spare parts are not being used. The electrical installation shall be carried out by a professional technician who will release documentation as requested by the laws in force. Packaging materials such as plastic bags, foam polystyrene, nails etc must be kept out of children's reach as dangers may arise.

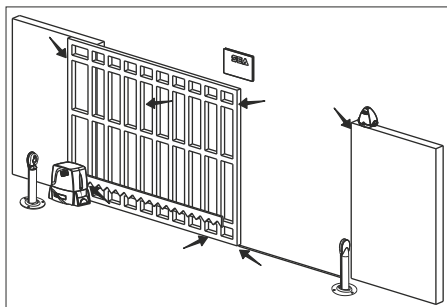

**INITIAL TEST AND STARTING OF THE AUTOMATION:** After having completed the necessary operations for a correct installation of the product and after having evaluated all the risks which could arise in any installation, **it is necessary to test the automation to guarantee the maximum security and, in particular, to guarantee that the laws in force are fully respected.** The first Start must be executed according to the rule **EN 12445** which establishes the methods of tests for checking the gate automation respecting the limits established by the rule **EN 12453**.

**SAFETY PRECAUTIONS:** All electrical work should comply with the current regulations. A 16A / 0,030 differential switch must be used. Separate the source cables (operators, power supply) and command cables (photocells, push-buttons, etc). Be sure the entire system is properly earth bonded. Always run cables in separate ducts to prevent interferences.

**INTENDED USE:** The operator has been designed to be used for the automation of sliding gates only.

**SPARE PARTS:** Send request for spare parts to: **SEA S.p.A. - Teramo - ITALY - [www.seateam.com](http://www.seateam.com)**

**SAFETY AND ENVIRONMENTAL COMPATIBILITY:** Don't waste product packing materials and/or circuits.

**STORAGE:** Materials must be properly packaged, handled with care and with appropriate vehicles;

STORAGE TEMPERATURE			
T <sub>min</sub>	T <sub>max</sub>	Humidity <sub>min</sub>	Humidity <sub>max</sub>
-30°C	+60°C	5% without condensation	90% without condensation

**WARRANTY LIMITS** - see the sales conditions

**MAINTENANCE AND DECOMMISSION:** must only be carried out by specialised and authorised personnel.

**THE MANUFACTURER CAN NOT BE DEEMED RESPONSIBLE FOR ANY DAMAGE OR INJURY CAUSED BY IMPROPER USE OF THIS PRODUCT;**

SEA S.p.A. reserves the right to make any required modification or change to the products and/or to this manual without any advanced notice obligation.

## TERMS OF SALES

**EFFICACY OF THE FOLLOWING TERMS OF SALE:** the following general terms of sale shall be applied to all orders sent to SEA S.p.A. All sales made by SEA to all costumers are made under the prescription of this terms of sales which are integral part of sale contract and cancel and substitute all apposed clauses or specific negotiations present in order document received from the buyer.

**GENERAL NOTICE** The systems must be assembled exclusively with SEA components, unless specific agreements apply. Non-compliance with the applicable safety standards (European Standards EM12453 – EM 12445) and with good installation practice releases SEA from any responsibilities. SEA shall not be held responsible for any failure to execute a correct and safe installation under the above mentioned standards.

**1) PROPOSED ORDER** The proposed order shall be accepted only prior SEA approval of it. By signing the proposed order, the Buyer shall be bound to enter a purchase agreement, according to the specifications stated in the proposed order.

On the other hand, failure to notify the Buyer of said approval must not be construed as automatic acceptance on the part of SEA.

**2) PERIOD OF THE OFFER** The offer proposed by SEA or by its branch sales department shall be valid for 30 solar days, unless otherwise notified.

**3) PRICING** The prices in the proposed order are quoted from the Price List which is valid on the date the order was issued. The discounts granted by the branch sales department of SEA shall apply only prior to acceptance on the part of SEA. The prices are for merchandise delivered ex-works from the SEA establishment in Teramo, not including VAT and special packaging. SEA reserves the right to change at any time this price list, providing timely notice to the sales network. The special sales conditions with extra discount on quantity basis (Qx, Qx1, Qx2, Qx3 formula) is reserved to official distributors under SEA management written agreement.

**4) PAYMENTS** The accepted forms of payment are each time notified or approved by SEA. The interest rate on delay in payment shall be 1.5% every month but anyway shall not be higher than the max. interest rate legally permitted.

**5) DELIVERY** Delivery shall take place, approximately and not peremptorily, within 30 working days from the date of receipt of the order, unless otherwise notified. Transport of the goods sold shall be at Buyer's cost and risk. SEA shall not bear the costs of delivery giving the goods to the carrier, as chosen either by SEA or by the Buyer. Any loss and/or damage of the goods during transport, are at Buyer's cost.

**6) COMPLAINTS** Any complaints and/or claims shall be sent to SEA within 8 solar days from receipt of the goods, proved by adequate supporting documents as to their truthfulness.

**7) SUPPLY** The concerning order will be accepted by SEA without any engagement and subordinately to the possibility to get it's supplies of raw material which is necessary for the production; Eventual completely or partially unsuccessful executions cannot be reason for complains or reservations for damage. SEA supply is strictly limited to the goods of its manufacturing, not including assembly, installation and testing. SEA, therefore, disclaims any responsibility for damage deriving, also to third parties, from non-compliance of safety standards and good practice during installation and use of the purchased products.

**8) WARRANTY** The standard warranty period is 12 months. This warranty time can be extended by means of expedition of the warranty coupon as follows:

**SILVER:** The mechanical components of the operators belonging to this line are guaranteed for 24 months from the date of manufacturing written on the operator.

**GOLD:** The mechanical components of the operators belonging to this line are guaranteed for 36 months from the date of manufacturing written on the operator.

**PLATINUM:** The mechanical components of the operators belonging to this line are guaranteed for 36 months from the date of manufacturing written on the operator. The base warranty (36 months) will be extended for further 24 months (up to a total of 60 months) when it is acquired the certificate of warranty which will be filled in and sent to SEA S.p.A. The electronic devices and the systems of command are guaranteed for 24 months from the date of manufacturing. In case of defective product, SEA undertakes to replace free of charge or to repair the goods provided that they are returned to SEA repair centre. The definition of warranty status is by unquestionable assessment of SEA. The replaced parts shall remain propriety of SEA. Binding upon the parties, the material held in warranty by the Buyer, must be sent back to SEA repair centre with fees prepaid, and shall be dispatched by SEA with carriage forward. The warranty shall not cover any required labour activities.

The recognized defects, whatever their nature, shall not produce any responsibility and/or damage claim on the part of the Buyer against SEA. The guarantee is in no case recognized if changes are made to the goods, or in the case of improper use, or in the case of tampering or improper assembly, or if the label affixed by the manufacturer has been removed including the SEA registered trademark No. 804888. Furthermore, the warranty shall not apply if SEA products are partly or completely coupled with non-original mechanical and/or electronic components, and in particular, without a specific relevant authorization, and if the Buyer is not making regular payments. The warranty shall not cover damage caused by transport, expendable material, faults due to non-conformity with performance specifications of the products shown in the price list. No indemnification is granted during repairing and/or replacing of the goods in warranty. SEA disclaims any responsibility for damage to objects and persons deriving from non-compliance with safety standards, installation instructions or use of sold goods. The repair of products under warranty and out of warranty is subject to compliance with the procedures notified by SEA.

**9) RESERVED DOMAIN** A clause of reserved domain applies to the sold goods; SEA shall decide autonomously whether to make use of it or not, whereby the Buyer purchases propriety of the goods only after full payment of the latter.

**10) COMPETENT COURT OF LAW** In case of disputes arising from the application of the agreement, the competent court of law is the tribunal of Teramo. SEA reserves the faculty to make technical changes to improve its own products, which are not in this price list at any moment and without notice. SEA declines any responsibility due to possible mistakes contained inside the present price list caused by printing and/or copying. The present price list cancels and substitutes the previous ones. The Buyer, according to the law No. 196/2003 (privacy code) consents to put his personal data, deriving from the present contract, in SEA archives and electronic files, and he also gives his consent to their treatment for commercial and administrative purposes.

**Industrial ownership rights:** once the Buyer has recognized that SEA has the exclusive legal ownership of the registered SEA brand num.804888 affixed on product labels and / or on manuals and / or on any other documentation, he will commit himself to use it in a way which does not reduce the value of these rights, he won't also remove, replace or modify brands or any other particularity from the products. Any kind of replication or use of SEA brand is forbidden as well as of any particularity on the products, unless preventive and expressed authorization by SEA.

**In accomplishment with art. 1341 of the Italian Civil Law it will be approved expressly clauses under numbers:**

**4) PAYMENTS - 8) GUARANTEE - 10) COMPETENT COURT OF LAW**

**English GENERAL NOTICE FOR THE INSTALLER AND THE USER**

1. Read carefully these **Instructions** before beginning to install the product. Store these instructions for future reference
2. Don't waste product packaging materials and /or circuits.
3. This product was designed and built strictly for the use indicated in this documentation. Any other use, not expressly indicated here, could compromise the good condition/operation of the product and/or be a source of danger. SEA S.p.A. declines all liability caused by improper use or different use in respect to the intended one.
4. The mechanical parts must be comply with Directives: Machine Regulation 2006/42/CE and following adjustments), Low Tension (2006/95/CE), electromgnetic Consistency (2004/108/CE) Installation must be done respecting Directives: EN12453 and En12445.
5. Do not install the equipment in an explosive atmosphere.
6. SEA S.p.A. is not responsible for failure to observe Good Techniques in the construction of the locking elements to motorize, or for any deformation that may occur during use.
7. Before attempting any job on the system, cut out electrical power and disconnect the batteries. Be sure that the earthing system is perfectly constructed, and connect it metal parts of the lock.
8. Use of the indicator-light is recommended for every system, as well as a warning sign well-fixed to the frame structure.
9. SEA S.p.A. declines all liability as concerns the automated system's security and efficiency, if components used, are not produced by SEAS.p.A..
10. For maintenance, strictly use original parts by SEA.
11. Do not modify in any way the components of the automated system.
12. The installer shall supply all information concerning system's manual functioning in case of emergency, and shall hand over to the user the warnings handbook supplied with the product.
13. Do not allow children or adults to stay near the product while it is operating. The application cannot be used by children, by people with reduced physical, mental or sensorial capacity, or by people without experience or necessary training. Keep remote controls or other pulse generators away from children, to prevent involuntary activation of the system.
14. Transit through the leaves is allowed only when the gate is fully open.
15. The User must not attempt to repair or to take direct action on the system and must solely contact qualified SEA personnel or SEA service centers. User can apply only the manual function of emergency.
16. The power cables maximum length between the central engine and motors should not be greater than 10 m. Use cables with 2,5 mm<sup>2</sup> section. Use double insulation cable (cable sheath) to the immediate vicinity of the terminals, in particular for the 230V cable. Keep an adequate distance (at least 2.5 mm in air), between the conductors in low voltage (230V) and the conductors in low voltage safety (SELV) or use an appropriate sheath that provides extra insulation having a thickness of 1 mm.

# CERTIFICATO DI ESTENSIONE GARANZIA

## CERTIFICATE OF WARRANTY EXTENTION

*n.* \_\_\_\_\_

### PRODOTTO/ PRODUCT

- Modello/*Model* \_\_\_\_\_  
- Matricola n. /*Serial Number* \_\_\_\_\_  
- Data di acquisto/*Date of order* \_\_\_\_\_  
- Data di installazione/*Date of installation* \_\_\_\_\_

Centrale/ <i>Control unit</i>	SEA <input type="checkbox"/>	Altri/ <i>Others</i>	<input type="checkbox"/>
Fotocelle/ <i>Photocells</i>	SEA <input type="checkbox"/>	Altri/ <i>Others</i>	<input type="checkbox"/>
RX - TX	SEA <input type="checkbox"/>	Altri/ <i>Others</i>	<input type="checkbox"/>
Altri accessori / <i>Other accessories</i>	SEA <input type="checkbox"/>	Altri/ <i>Others</i>	<input type="checkbox"/>

### UTENTE/*Customer*

Nome e Cognome \_\_\_\_\_  
*First Name and Family Name* \_\_\_\_\_  
Indirizzo/*Address* \_\_\_\_\_  
\_\_\_\_\_

### INSTALLATORE/*Installer*

Ragione sociale/*Company Name* \_\_\_\_\_  
Nome e Cognome/*First and Family Name* \_\_\_\_\_  
Indirizzo/*Address* \_\_\_\_\_

### INSTALLATORE/INSTALLER

Firma per il trattamento dei dati personali ai sensi del Regolamento UE 679/2016  
Agreement to the GDPR EU Regulation No. 679/2016

Copia da restituire  
*Copy to be returned*

Firma e Timbro

*Sign and Stamp* \_\_\_\_\_

N.B: L'estensione della garanzia legale di 12 mesi a 24 mesi e 36 mesi è valida solo se il presente modulo viene rispedito per posta o fax a SEA S.p.A. entro 15gg dalla data di acquisto. Allegare relativa fattura d'acquisto.

Note: The extension of the legal standard warranty of 12 months to 24 months and to 36 months, is valid only if the present form is returned by mail or fax to SEA S.p.A within 15days from the date of purchase. Attach customer invoice.



**SEA**<sup>®</sup>  
Sistemi Elettronici  
di Apertura Porte e Cancelli  
International registered trademark n. 804888

SEA S.p.A. - Zona Industriale San Atto- 64020 Teramo (Italy)  
Phone +39 0861 588341- Fax +39 0861588344  
[www.seateam.com](http://www.seateam.com) - [info@seateam.com](mailto:info@seateam.com)

**Dichiarazione di conformità**  
**Declaration of Conformity**

La SEA S.p.A. dichiara sotto la propria responsabilità e, se applicabile, del suo rappresentante autorizzato che, con l'installazione degli adeguati dispositivi di sicurezza e di filtraggio disturbi, i prodotti:  
*SEA S.p.A. declares under its proper responsibility and, if applicable, under the responsibility of its authorised representative that, by installing the appropriate safety equipment and noise filtering, the products:*

<b>Descrizione / Description</b>	<b>Modello / Model</b>	<b>Marca / Trademark</b>
<b>Saturn 600</b>	12400207	SEA
<b>Saturn 1000</b>	12400120	SEA
<b>Saturn 1200 OIL 24V</b>	12400280	SEA
<b>Saturn 1500 OIL 24V</b>	12400285	SEA
<b>Saturn 800 BR 36V FM</b>	12400270	SEA
<b>Saturn 800 BR 36V FI</b>	12400400	SEA

(e tutti i derivati / *and all the by-products*)

<b>Boxer 600</b>	12400210	SEA
<b>Boxer 1000</b>	12405000	SEA
<b>Boxer 1300 Inverter</b>	12405001	SEA
<b>Boxer 2000 Inverter</b>	12405295	SEA

(e tutti i derivati / *and all the by-products*)

sono costruiti per essere incorporati in una macchina o per essere assemblati con altri macchinari per costruire una macchina ai sensi della Direttiva 2006/42/CE  
*are built to be integrated into a machine or to be assembled with other machinery to create a machine under the provisions of Directive 2006/42/CE*

sono conformi ai requisiti essenziali di sicurezza relativi ai prodotti entro il campo di applicabilità delle Direttive Comunitarie 2014/35/UE e 2014/30/UE  
*are conforming to the essential safety requirements related to the products within the field of applicability of the Community Directives 2014/35/UE and 2014/30/UE*

**COSTRUTTORE o RAPPRESENTANTE AUTORIZZATO:**  
**MANUFACTURER or AUTHORISED REPRESENTATIVE:**

**SEA S.p.A.**  
DIREZIONE E STABILIMENTO:  
Zona industriale 64020 S.ATTO Teramo - (ITALY)  
Tel. +39 0861 588341 r.a. Fax +39 0861 588344  
[Http://www.seateam.com](http://www.seateam.com)

Luogo, data di emissione  
*Place, date of issue*  
Teramo, 05/02/2021

L'Amministratore  
The Administrator  
Ernio Di Saverio  



## Automatic Gate Openers

Questo articolo è stato prodotto seguendo rigide procedure di lavorazione ed è stato testato singolarmente al fine di garantire i più alti livelli qualitativi e la vostra soddisfazione. Vi ringraziamo per aver scelto SEA.

This item has been produced following strict production procedures and has been singularly tested for the highest quality levels and for your complete satisfaction.  
Thanks for choosing SEA.

Cet article a été produit suivant des procédures d'usinage strictes et il a singulièrement été testé afin de garantir les plus hauts niveaux de qualité pour votre satisfaction.  
Nous vous remercions d'avoir choisi SEA.

Este artículo ha sido producido siguiendo rigidos procedimientos de elaboración y ha sido probando singolarmente a fin de garantizar los mas altos niveles de calidad y vuestra satisfaccion.  
Le agradecemos por haber escogito SEA.





**Automatic Gate Openers**

International registered trademark n. 804888

**SEA S.p.A.**

**Zona industriale 64020 S.ATTO Teramo - (ITALY)**

**Tel. +39 0861 588341 r.a. Fax +39 0861 588344**

**[www.seateam.com](http://www.seateam.com)**

**[seacom@seateam.com](mailto:seacom@seateam.com)**